



OF Series LED Panel

## DOOH Advertising Revolution

DOOH (Digital out-of-home) advertising is a key component for industry growth, while traditional OOH remains steady.



Ultra Slim & Light

Ultra slim & lightweight panels improve installation efficiency.



## Fully Clad Aluminum Housing Design

5VB Flame Retardant

Unlike traditional plastic housing, the fully clad aluminum design allows the display to function properly in hot and environments.

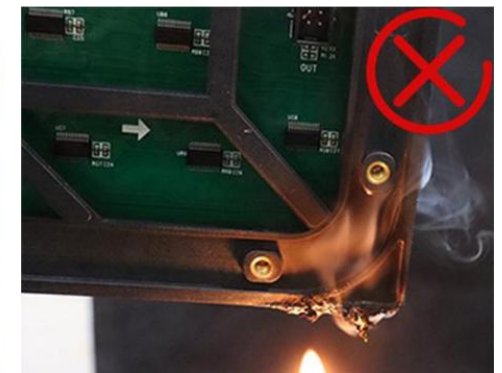
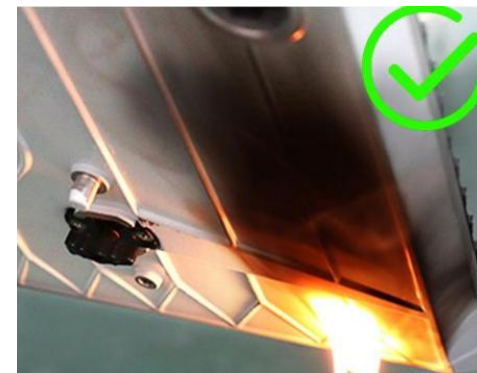

All-Weather Stability

Ingress Protection

High waterproof protection from the front and back results in more secure and steady performance all the time.

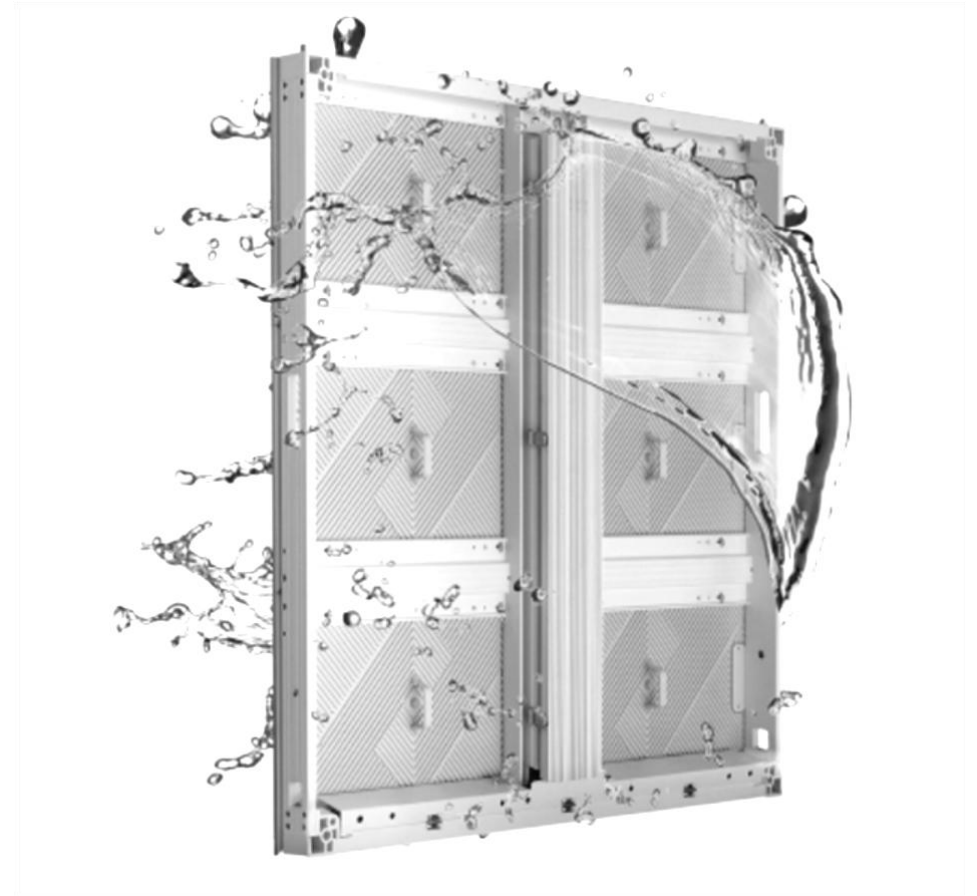

## Double Serviceability

Supports both front & rear installation and maintenance with universal modules.

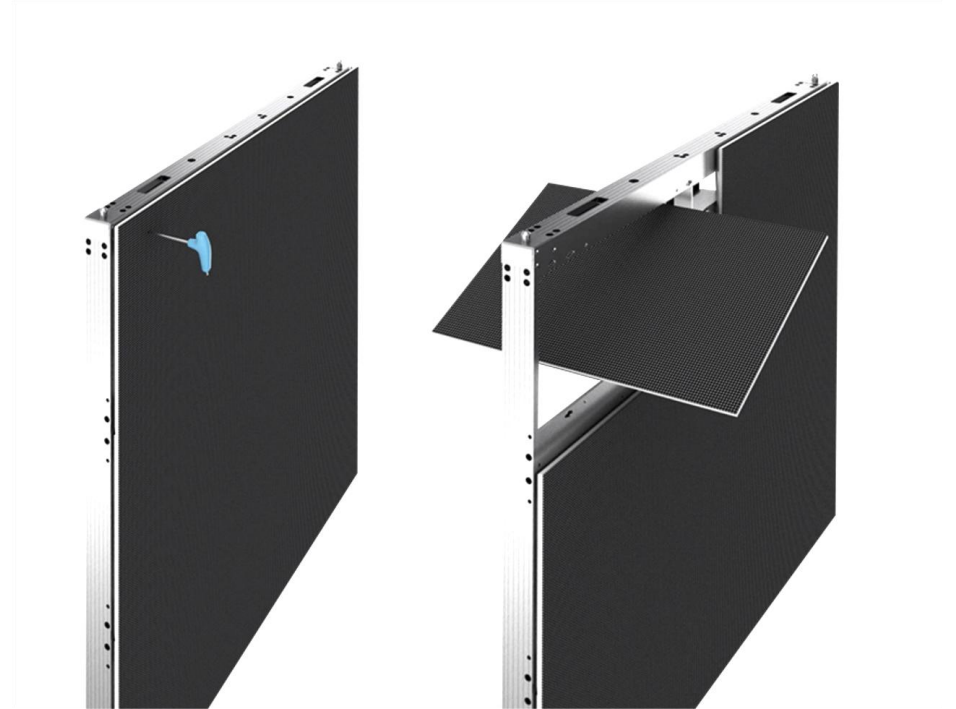

## Direct Connections

Direct connections between modules and HUB, free of flat ribbon cables for a greater level of stability.



## Creative Splicing

45 ° bevel is optional to splice L shapes, cubes and etc. to realize more creativity.

\* if need bevel design let sales know before placing order

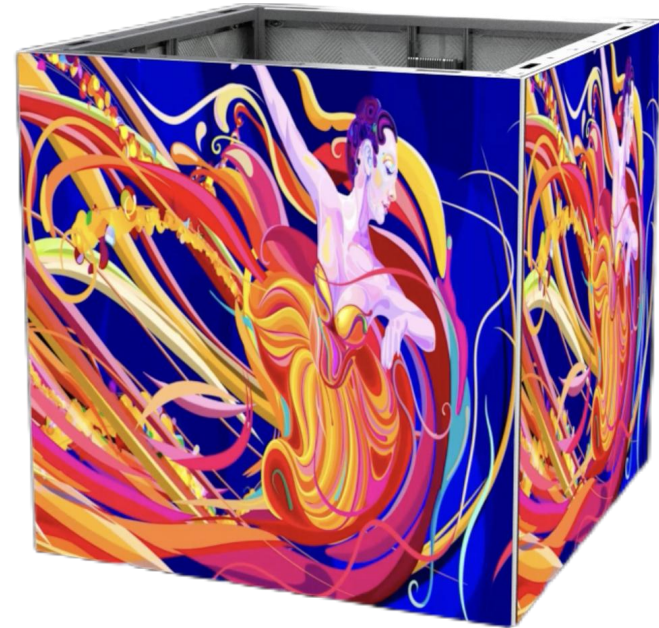



Market Trends

Naked Eye 3D Solution

L-shaped and curved splicing get better naked  
eye 3D Effect





High Energy Efficiency

Good Heat Dissipation

Applying dual-channel voltage input to reduce power consumption to improve conversion efficiency

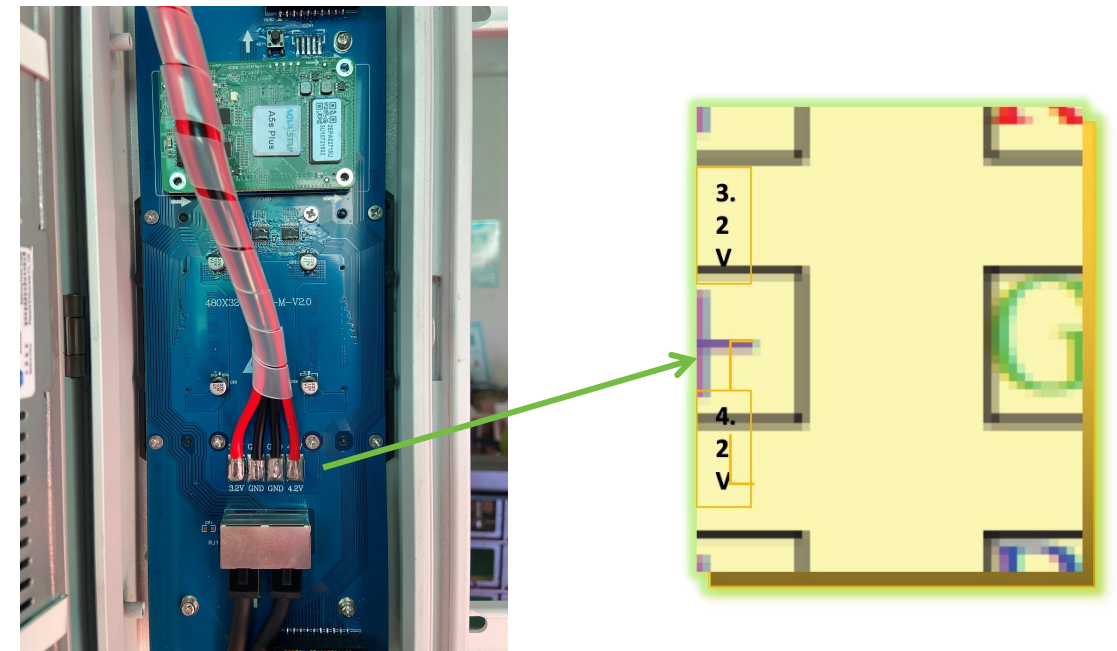

## Installation

Flexibility to choose the best installation method according to the construction site.

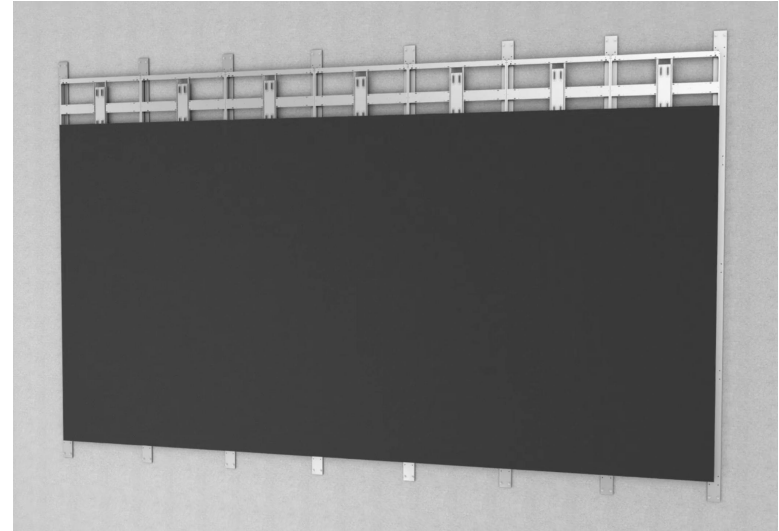

Bracket

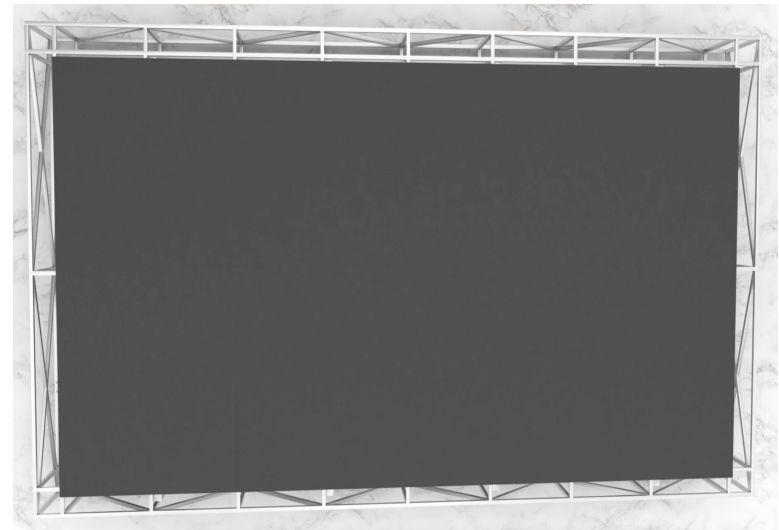

Steel Structure

## Parameters

Model	OF-5	OF-6	OF-8	OF-10
Pixel Pitch	5.7mm	6.67mm	8mm	10mm
LED Encapsulation	SMD2727	SMD2727	SMD2727	SMD2727
Cabinet Resolution	168x168dots	144x144dots	384x288dots	344x258dots
Brightness	>6,500nits	>6,500nits	>6,500nits	>6,500nits
Viewing Angle	160 ° H   140 ° V	160 ° H   140 ° V	160 ° H   140 ° V	160 ° H   140 ° V
Refresh Rate	3,840Hz +/-	3,840Hz +/-	3,840Hz +/-	3,840Hz +/-
Panel Size	960mm x 960mm	960mm x 960mm	960mm x 960mm	960mm x 960mm
Cabinet Material	Aluminum	Aluminum	Aluminum	Aluminum
Weight	28kg	28kg	28kg	28kg

## Application

